



# Wind Resistant Offset Gutter

## Installation Guide for Wind Resistant Offset Gutter

4 COMMERCE WAY, ARDEN, NC 28704 USA  
800-892-9173 828-676-1700  
OMGEDGESYSTEMS.COM



**EdgeSystems**



# Installation Guide for Wind Resistant Offset Gutter

**APPROVALS:** Contact manufacturer for verification of test report data on your project.



ANSI/SPRI/GT-1 TEST PRESSURES UP TO 136 PSF (VERTICAL), AND 223 PSF (HORIZONTAL)

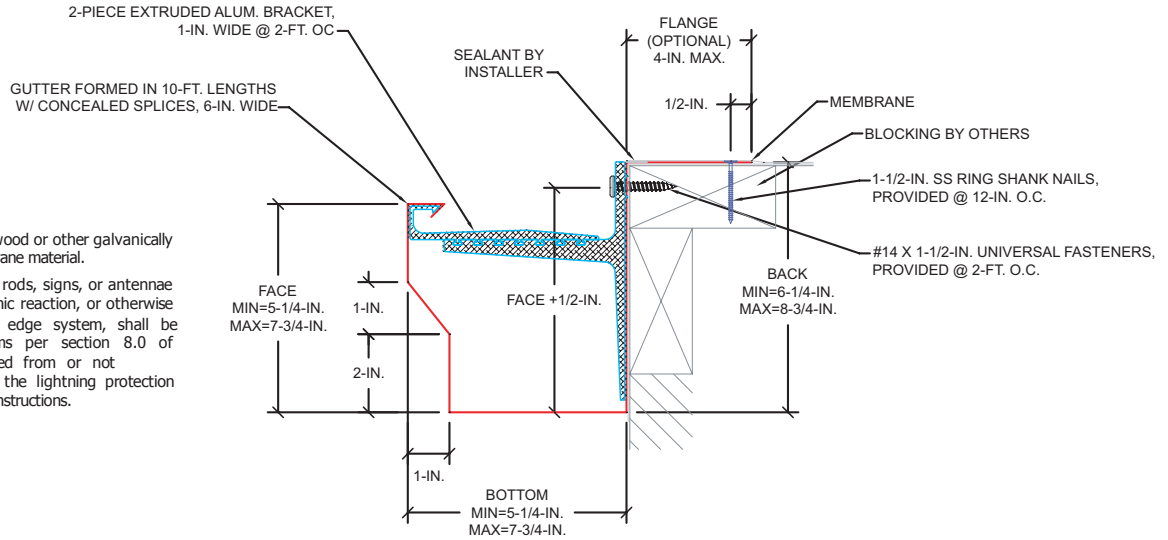

**NOTES:**

#1 - Isolate all metal parts from ACQ treated wood or other galvanically incompatible material with appropriate membrane material.

#2 - Appliance attachments, such as lightning rods, signs, or antennae that penetrate the water seal, induce a galvanic reaction, or otherwise compromise the effectiveness of the roof edge system, shall be eliminated or isolated to prevent problems per section 8.0 of ANSI/SPRI/GT-1. Appliances shall be isolated from or not attached to the roof edge system. Consult the lightning protection system manufacturer for specific attachment instructions.

BOTTOM SIZES ARE PROVIDED IN 1/2-IN. INCREMENTS  
(e.g. 5-1/4-IN., 5-3/4-IN., 6-1/4-IN., . . . )

FOR MASONRY APPLICATIONS, PLEASE CONTACT OMG.

CONTACT OMG FOR APPROPRIATE RECOMMENDATIONS NEEDED TO  
MEET/EXCEED ANSI/SPRI/GT-1 DESIGN CRITERIA

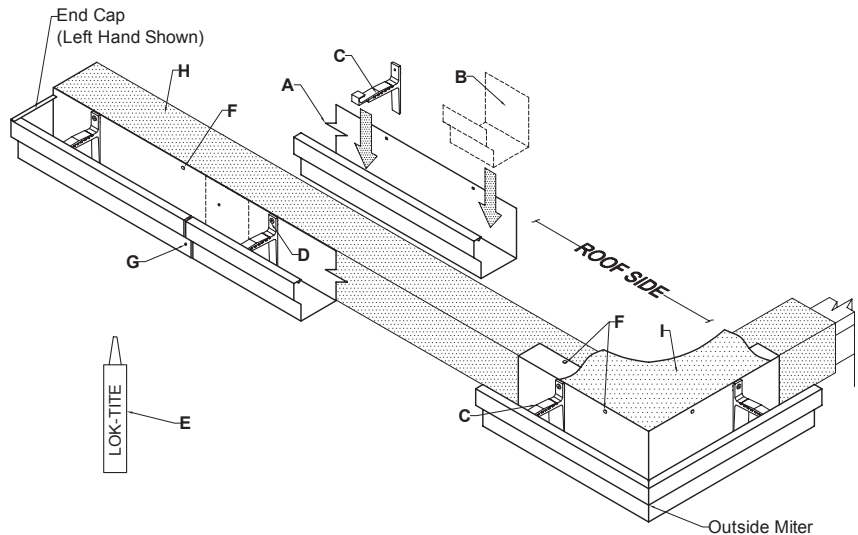

- A. Formed Gutter**  
10-ft. Lengths
- B. Concealed Joint Splice**  
6-in. Lengths
- C. Extruded Alum. Bracket**  
1-in. Length @ 24-in. OC
- D. #14 x 1 1/2-in. Universal Fastener**  
at All Bracket Locations  
(Included & Required)

- E. Lok-Tite**  
at All Brackets  
(Included & Required)
- F. 1 1/2-in. SS Ring Shank Nail**  
(Included & Required)
- G. Aluminum Pop-Rivet**  
(Included & Required)
- H. Base Ply Membrane**  
(By Others)
- I. Strip-In Ply**  
(By Installer)

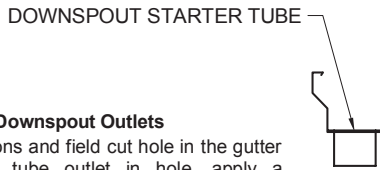

### STEP 1: Installing Downspout Outlets

Determine outlet locations and field cut hole in the gutter bottom. Insert starter tube outlet in hole, apply a continuous bead of non-curing sealant to flange and fasten with (2) pop rivets in each flange from outside.

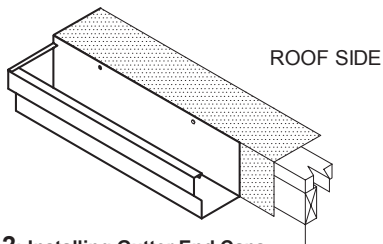

### STEP 2: Installing Gutter End Caps

Locate the end caps for the appropriate locations. Secure to the roof edge using the 1½-in. ss ring shank nails (provided) in every other pre-punched hole. If optional roof flange is included install 1½-in. ss ring shank nails in all holes in roof flange.

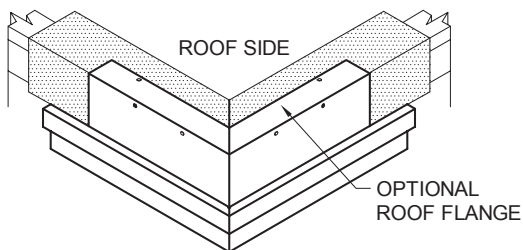

### STEP 3: Installing Gutter Miters

Locate the miters for the appropriate locations. Secure to the roof edge using the 1½-in. ss ring shank nails (provided) in every other pre-punched holes. If optional roof flange is included install 1½-in. ss ring shank nails in all holes in roof flange.

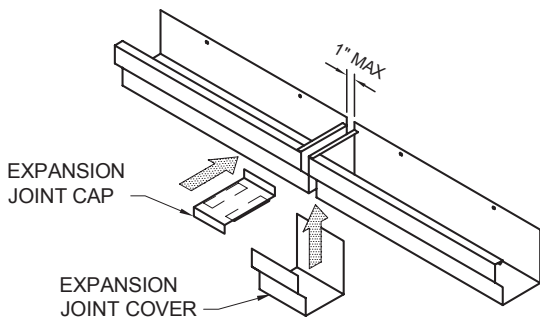

### STEP 4: Installing Expansion Joints (If Required)

Install expansion joint in location as specified on roof plan(s). An expansion joint will consist of (2) pre-fabricated end caps, (1) expansion joint cap and (1) expansion joint cover. Gap the end caps at 1-in. max. Slide the joint cover onto the gutter, then pop rivet the joint cover in the same locations as shown in FIGURE 2. Place the joint cap over the end cap lips and center the joint cap over the gap, secure in place using the 1½-in. ss ring shank nails (provided).

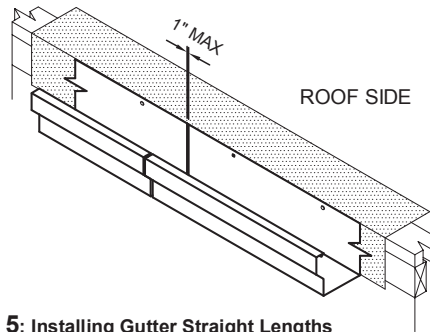

### STEP 5: Installing Gutter Straight Lengths

Begin from the end caps/miters working inward to the center. Allow ¼-in. gap between gutter sections for thermal expansion. Review lengths of all straight pieces prior to cutting to avoid creating relatively short sections of cap adjacent to full length section.

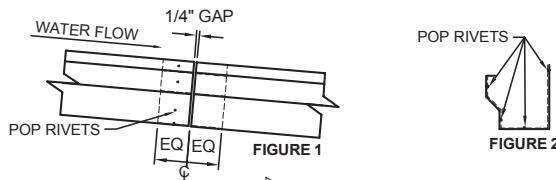

### STEP 6: Installing Gutter Joint Splices

Locate the joint splice for the appropriate gutter. Apply a continuous bead of non-curing sealant to both sides of the joint. Slide the joint splice down into the gutter. Secure the joint splice in place by pop riveting it on the high side of the joint (FIGURE 1) on the 3 surfaces as shown in FIGURE 2. There must be a joint splice at every joint.

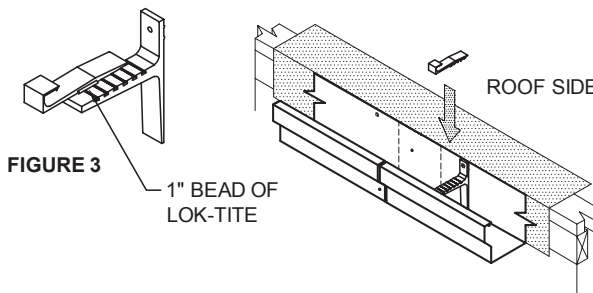

### STEP 7: Installing Gutter Brackets

Install the bracket base first, secure it in place using the #14 x 1½-in. screw (provided). Then hook the top part of the bracket on the face lip of the gutter. Slide the top onto the base by ¼-in. (MAX), then apply a 1-in. (MIN) continuous bead of Lok-Tite (provided) as shown in FIGURE 3. Then continue sliding the top onto the base, until they are aligned. The brackets should be installed at the pre-punched hole adjacent to the fasteners previously installed (24-in. OC max).